

# LAUDA CIRCULATION CHILLERS

## Specific application examples

---

- Rotary evaporators
- Distillation systems
- Spectrometers
- Supply of cooling traps
- Digital printing
- Laser cutting
- Laser sorting
- Point welding
- Injection molding
- Tunnel drilling machines
- Centralized cooling water supply



# LAUDA Microcool

Circulation chillers for reliable continuous operation in laboratory and research applications from  $-10$  to  $40$  °C

$-10$  °C   $40$  °C

## Compact circulation chillers with outstanding price-performance ratio

The LAUDA Microcool line of user-friendly circulation chillers consists of four compact models with large LED display and membrane keypad, offering cooling capacities of 0.25 to 1.2 kW. The highlight of these devices is the premium quality centrifugal pump with magnetic coupling – unique to this price category: Magnetic coupling of pump and electric motor prevents any kind of seal issue from arising on the pump shaft, eliminating the chance for any fluid to leak.



Illuminated viewing glass enables quick identification of the fill level



Standard-issue RS 232 interface and alarm contact

## PUMP CHARACTERISTICS Water

Pressure bar

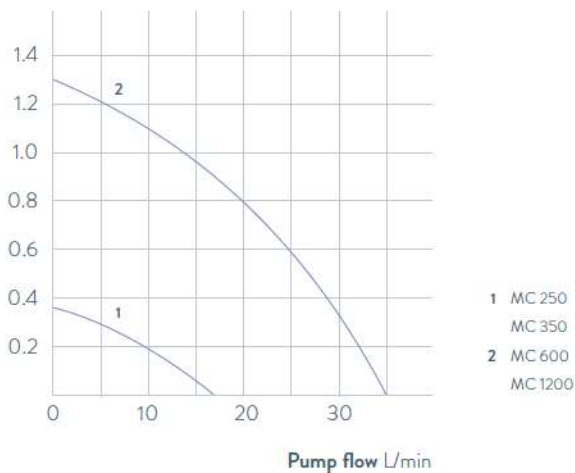

## Important functions

- Auto-start timer and auto shutdown function
- Filling opening at the top, drain connection at the rear
- Cooling capacity adapted via solenoid valve control, including automatic compressor control

## Included accessories

Nipples, screw caps

## Further accessories

Tubing

All technical data and power supply variants can be found in the »Technical data« section.

More at [www.lauda.de/1764](http://www.lauda.de/1764)



### LAUDA Microcool

The compact circulation chillers MC 250 and MC 350 fit effortlessly on a lab bench. Somewhat larger models are also available having 600 and 1200 watts of cooling capacity and which can be positioned on the floor under a lab bench to save space.

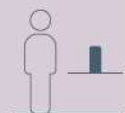



# LAUDA Circulation chillers

## Device type overview

LAUDA Microcool / Page 116



LAUDA Ultracool / Page 118

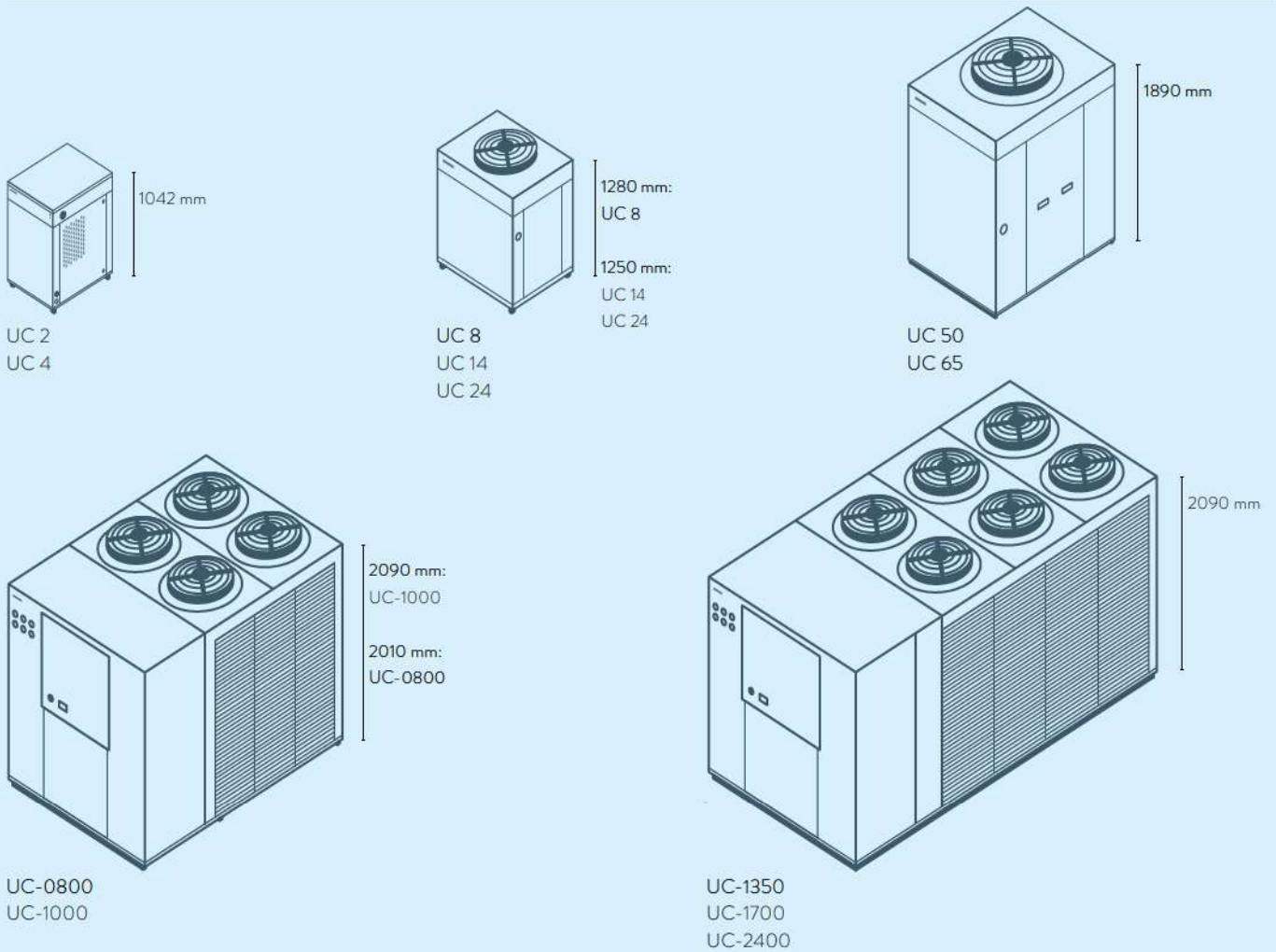

# LAUDA Circulation chillers

## Interfaces

	Pt 100 (1)	Pt 100 (2)	USB	Ethernet	RS 232 / 485	Analog	Namur contact	D-Sub contact	PROFIBUS	EtherCAT M8	EtherCAT RJ 45	Modbus	Malfunction contact	Number of module slots, large	Number of module slots, small
LAUDA Microcool / Page 116	-	-	-	-	RS 232	-	-	-	-	-	-	-	S	-	-
LAUDA Ultracool / Page 118	-	-	-	S*	-	-	-	-	-	-	-	-	S	-	-

S = Series standard

S\* = Ethernet with Modbus TCP/IP protocol

# LAUDA Circulation chillers

## Function overview

Operating element	Microcool	Ultracool
Display	7-Segment	LCD
Mode of operation	3-button	6-button
1-point calibration	✓	-
Programmer, programs/segments	-	-
Programmer, tolerance range function	-	-
Graphic temperature profile display	-	-
Pump pressure display (analog)	- / ✓	✓
Pump pressure display (digital)	-	✓
Adjustable bypass	-	-
Level indicator (analog)	✓	-
Level indicator (digital)	-	✓
Standby timer	✓	✓
Flow control instrument	-	-
Overflow	✓	-
Low-level alarm	✓	✓
Drain tap	-	✓
Drain screw	✓	-





# LAUDA Circulation chillers

Technical data according to DIN 12876 standard

Device type	Working temperature range °C	Temperature stability* ±K	Ambient temperature range °C	Cooling of the refrigerating machine	Heater power max. kW	Cooling output kW					Pump pressure max. bar	Pump flow max. pressure L./min	Pump connection thread mm	Bath volume min. L
						20 °C	10 °C	0 °C	-10 °C	-20 °C				
LAUDA Microcool / Page 116														
MC 250	-10 ... 40	0.50	5 ... 40	Air	-	0.25	0.20	0.15	0.09	-	0.35	16	Ø 10 mm	2.0
MC 350	-10 ... 40	0.50	5 ... 40	Air	-	0.35	0.27	0.20	0.12	-	0.35	16	Ø 10 mm	4.0
MC 600	-10 ... 40	0.50	5 ... 40	Air	-	0.60	0.50	0.36	0.15	-	1.3	35	G 3/4	4.0
MC 1200	-10 ... 40	0.50	5 ... 40	Air	-	1.20	1.05	0.75	0.40	-	1.3	35	G 3/4	7.0

Bath volume max. L	Dimensions (W x D x H) mm	Protection Rating	Noise level dB (A)	Weight kg	Loading max. kW	Power supply V; Hz	Part Number	Device type
4.0	200 x 350 x 465	IP 32	60	25.0	0.2	230 V; 50 Hz & 220 V; 60 Hz	L001046	MC 250
7.0	240 x 400 x 500	IP 32	60	34.0	0.5	230 V; 50 Hz	L001047	MC 350
8.0	350 x 480 x 595	IP 32	57	50.0	0.7	230 V; 50 Hz	L001048	MC 600
14.0	450 x 550 x 650	IP 32	59	63.0	1.2	230 V; 50 Hz	L001049	MC 1200

# LAUDA Circulation chillers

## Technical data

Device type	Working temperature range °C	Temperature stability ±K	Ambient temperature range °C	Cooling output at water outlet temperature <sup>1</sup> kW								Number of refrigerant circuits			Motor fan		Max. discharge pressure bar
				35 - 25 °C	20 °C	15 °C	10 °C	5 °C	0 °C	-5 °C	-10 °C	No.	kW	m <sup>3</sup> /h			
LAUDA Ultracool / Page 118																	
UC 2	-10...35	0.5	-15...50	3.10	3.10	2.80	2.40	2.00	1.70	1.40	1.20	1	1	0.2	3050	3.4	
UC 2	-10...35	0.5	-15...50	3.10	3.10	2.80	2.40	2.00	1.70	1.40	1.20	1	1	0.2	3050	5.5	
UC 4	-10...35	0.5	-15...50	6.10	6.10	5.50	4.80	3.90	3.30	2.80	2.40	1	1	0.2	3050	3.4	
UC 4	-10...35	0.5	-15...50	6.10	6.10	5.50	4.80	3.90	3.30	2.80	2.40	1	1	0.2	3050	5.5	
UC 8	-10...35	0.5	-15...50	13.3	13.3	12.0	10.2	8.5	7.0	5.4	4.4	1	1	0.5	4500	5.6	
UC 8	-10...35	0.5	-15...50	13.3	13.3	12.0	10.2	8.5	7.0	5.4	4.4	1	1	0.5	4500	4.2	
UC 14	-10...35	0.5	-15...50	22.4	20.3	18.4	15.8	13.4	11.1	9.3	7.6	1	1	1.0	7500	5.6	
UC 14	-10...35	0.5	-15...50	22.4	20.3	18.4	15.8	13.4	11.1	9.3	7.6	1	1	1.0	7500	4.2	
UC 24	-10...35	0.5	-15...50	34.0	30.9	28.1	24.3	20.8	17.3	14.5	12.0	1	1	1.0	7500	5.8	
UC 24	-10...35	0.5	-15...50	34.0	30.9	28.1	24.3	20.8	17.3	14.5	12.0	1	1	1.0	7500	4.2	
UC 50	-10...35	0.5	-15...50	67.5	65.6	59.4	51.2	43.7	36.4	30.4	25.2	1	1	2.6	19000	6.5	
UC 50	-10...35	0.5	-15...50	67.5	65.6	59.4	51.2	43.7	36.4	30.4	25.2	1	1	2.6	19000	4.6	
UC 65	-10...35	0.5	-15...50	87.5	85.2	77.4	66.9	57.3	47.8	40.1	33.3	1	1	2.6	19000	6.9	
UC 65	-10...35	0.5	-15...50	87.5	85.2	77.4	66.9	57.3	47.8	40.1	33.3	1	1	2.6	19000	5.0	
UC-0800	-5...25	2	-15...45	114.3	114.3	103.0	87.9	72.3	57.8	45.4	-	2	4	2.4	36000	4.6	
UC-1000	-5...25	2	-15...45	140.8	140.8	126.1	106.4	85.9	67.0	51.2	-	2	4	2.4	40800	3.7	
UC-1350	-5...25	2	-15...45	182.1	182.1	163.7	139.2	113.7	90.0	69.8	-	2	6	3.6	57000	5.5	
UC-1700	-5...25	2	-15...45	228.4	228.4	205.9	175.7	144.6	115.6	90.8	-	2	6	3.6	55200	5.2	
UC-2400	-5...25	2	-15...45	336.9	336.9	308.8	265.0	223.1	182.8	148.2	-	2	6	7.5	66000	5.2	

<sup>1</sup> at 25 °C ambient temperature

<sup>2</sup> Rp = G = BSP (internal screw thread acc. to British Standard Pipe)

Correction factor ambient temperature;  $C_{NOM} = C_{WORK} \times F$

Ambient temperature	25	30	35	40	45
Correction factor F	1	0.9	0.85	0.78	0.66

Note: The values calculated with the correction factors are only approximated values

Pump flow max. L/min	Nominal discharge pressure bar	Pump flow nominal L/min	Pump connection thread? mm	Volume water tank L	Dimensions (W x D x H) mm	Protection Rating	Noise level <sup>1</sup> dB (A)	Weight kg	Loading max. kW	Max. fuse A	Power supply V; Hz	SEPR	Part Number	Device type
42	3.3	5.6	Rp 1/2	12	510×680×1042	IP 32	53.5	115	1.0	16	230 V; 50 Hz	6.24	L003509	UC 2
68	5.3	5.6	Rp 1/2	12	510×680×1042	IP 32	53.5	115	1.2	16	230 V; 50 Hz	6.24	L003510	UC 2
42	2.8	13.8	Rp 1/2	12	510×680×1042	IP 32	57.9	115	1.8	16	230 V; 50 Hz	5.23	L003511	UC 4
68	5.0	13.8	Rp 1/2	12	510×680×1042	IP 32	57.9	115	2.0	16	230 V; 50 Hz	5.23	L003512	UC 4
133	5.3	26.6	Rp 1	35	720×910×1280	IP 54	61.0	150	3.8	25	400 V; 3/PE; 50 Hz	6.44	L002944	UC 8
130	4.0	26.6	Rp 1	35	720×910×1280	IP 54	61.0	150	3.4	25	400 V; 3/PE; 50 Hz / 460 V; 3/PE; 60 Hz	6.44	L002853	UC 8
133	5.3	43.8	Rp 1	35	720×910×1250	IP 54	64.7	175	5.4	25	400 V; 3/PE; 50 Hz	6.41	L002946	UC 14
130	3.7	43.8	Rp 1	35	720×910×1250	IP 54	64.7	175	5.1	25	400 V; 3/PE; 50 Hz / 460 V; 3/PE; 60 Hz	6.41	L002854	UC 14
200	4.9	84.1	Rp 1	35	720×910×1250	IP 54	64.7	180	9.5	32	400 V; 3/PE; 50 Hz	5.63	L002947	UC 24
130	2.7	84.1	Rp 1	35	720×910×1250	IP 54	64.7	180	8.0	32	400 V; 3/PE; 50 Hz / 460 V; 3/PE; 60 Hz	5.63	L002855	UC 24
250	5.5	150.0	Rp 1 1/2	210	1040×1435×1890	IP 54	68.7	410	16.5	50	400 V; 3/PE; 50 Hz	5.37	L002948	UC 50
230	3.3	150.0	Rp 1 1/2	210	1040×1435×1890	IP 54	68.7	410	14.8	50	400 V; 3/PE; 50 Hz / 460 V; 3/PE; 60 Hz	5.37	L002856	UC 50
367	6.5	196.0	Rp 1 1/2	210	1040×1435×1890	IP 54	69.5	440	23.6	63	400 V; 3/PE; 50 Hz	5.16	L002949	UC 65
250	3.3	196.0	Rp 1 1/2	210	1040×1435×1890	IP 54	69.5	440	20.4	63	400 V; 3/PE; 50 Hz / 460 V; 3/PE; 60 Hz	5.16	L002857	UC 65
420	3.4	247.0	Rp 2	300	1545×2230×2010	IP 54	58.3	1020	27.5	80	400 V; 3/PE; 50 Hz	-	E6080223	UC-0800
500	3.5	299.0	Rp 2 1/2	500	1660×3400×2090	IP 54	63.1	1460	33.4	100	400 V; 3/PE; 50 Hz	-	E6100221	UC-1000
500	4.5	392.0	Rp 2 1/2	500	1660×3400×2090	IP 54	62.2	1570	43.8	150	400 V; 3/PE; 50 Hz	-	E6135221	UC-1350
670	3.4	494.0	Rp 2 1/2	500	1660×3400×2090	IP 54	61.3	1630	54.9	150	400 V; 3/PE; 50 Hz	-	E6170221	UC-1700
970	3.6	733.0	DIN-2566 DN80	500	1660×3585×2090	IP 54	62.7	1690	71.4	200	400 V; 3/PE; 50 Hz	-	E6240221	UC-2400

# LAUDA Circulation chillers

## Power supply variants

Device type	Power supply V; Hz	Pump pressure max. bar	Pump flow max. pressure L./min	Loading max. kW	Plug code*	Part Number	Device type	Power supply V; Hz	Pump pressure max. bar	Pump flow max. pressure L./min	Loading max. kW	Plug code*	Part Number
<b>LAUDA Microcool / Page 116</b>													
MC 250	115 V; 60 Hz	0.4	16	0.2	14	L001066	MC 600	115 V; 60 Hz	1.3	35	0.8	14	L001068
MC 250	220 V; 60 Hz	0.4	16	0.2	43	L001061	MC 600	220 V; 60 Hz	1.3	35	0.7	43	L001063
MC 350	100 V; 50/60 Hz	0.4	16	0.5	14	L001072	MC 1200	115 V; 60 Hz	1.3	35	1.1	14	L001069
MC 350	115 V; 60 Hz	0.4	16	0.5	14	L001067	MC 1200	220 V; 60 Hz	1.3	35	1.2	43	L001064
MC 350	220 V; 60 Hz & 230 V; 50 Hz	0.4	16	0.5	42	L001052							
<b>LAUDA Ultracool / Page 118</b>													
UC 2	230 V; 60 Hz	3.5	50	1.1	-	L003513	UC-1000	460 V; 3/PE; 60 Hz	5.2	430	42.1	-	E6100241
UC 2	230 V; 60 Hz	5.0	80	1.3	-	L003533	UC-1350	460 V; 3/PE; 60 Hz	5.4	600	55.3	-	E6135241
UC 4	230 V; 60 Hz	3.5	50	1.9	-	L003514	UC-1700	460 V; 3/PE; 60 Hz	5.4	600	70.2	-	E6170241
UC 4	230 V; 60 Hz	5.0	80	2.1	-	L003534	UC-2400	460 V; 3/PE; 60 Hz	3.7	1170	96.1	-	E6240241
UC-0800	460 V; 3/PE; 60 Hz	4.8	300	35.4	-	E6080241							

\*All data for the plug codes can be found on page 162



# LAUDA Circulation chillers

## More characteristics

LAUDA Ultracool / Page 118

**PUMP CHARACTERISTIC** Water

Pressure bar

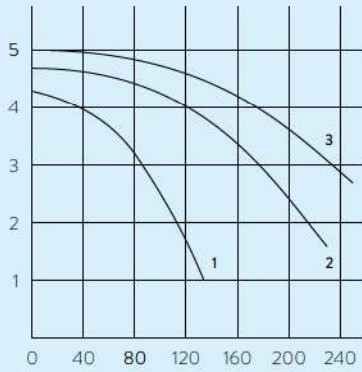

Pump flow L/min

- 3 UC 65
- 2 UC 50
- 1 UC 8, UC 14, UC 24

**PUMP CHARACTERISTIC** Water

Pressure bar

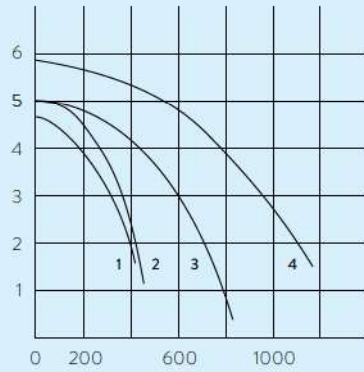

Pump flow L/min

- 1 UC-0800
- 2 UC-1000
- 3 UC-1350
- UC-1700
- 4 UC-2400

**PUMP CHARACTERISTIC** Water

Pressure bar

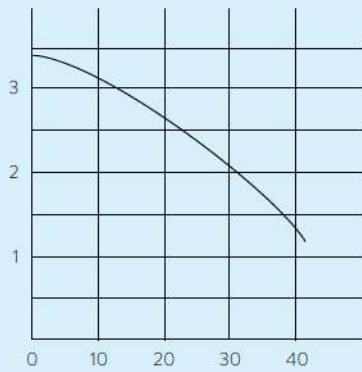

Flow rate L/min

- UC 2, UC 4